

MASTER 4-5

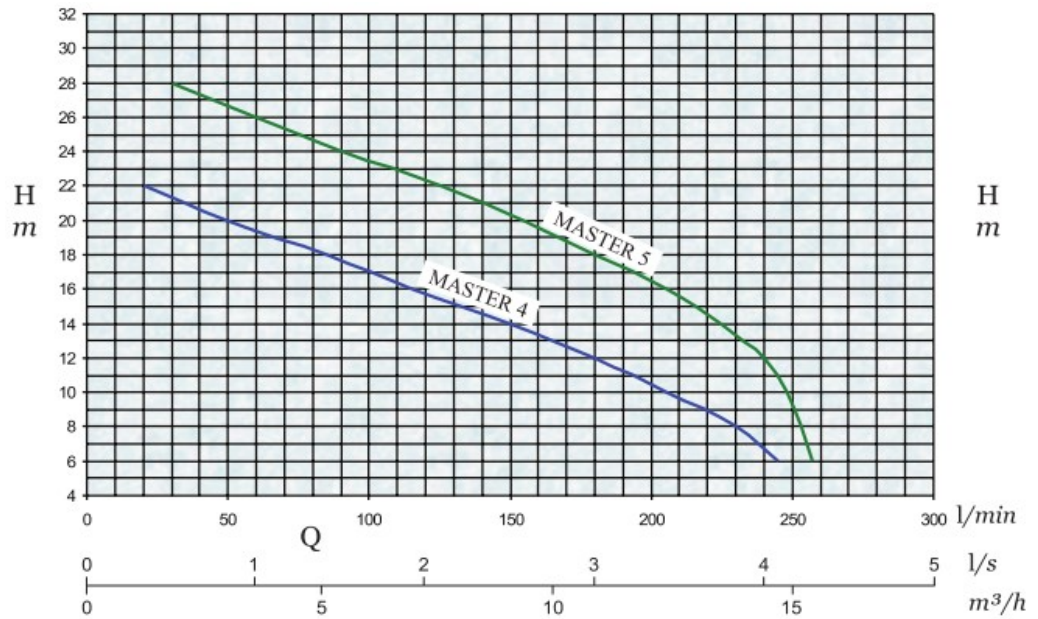

Passage libre 7 mm
Freier Durchgang 7 mm
Passaggio libero 7 mm



Type Typ Tipo	n [t/min] [U/min]	P [kW]	1 ~ 230 V		3 ~ 400 V	f [Hz]	DN [DN]	DN3 ["G"]	Poids [kg] Gewicht [kg] Peso [kg]
			I [A]	C [μF]					
MASTER 4 M/T (A)	2850	1.5	11	40 +70	3.8	50	40	2"	37
MASTER 5 T	2850	2.2	-	-	5.3	50	40	2"	39

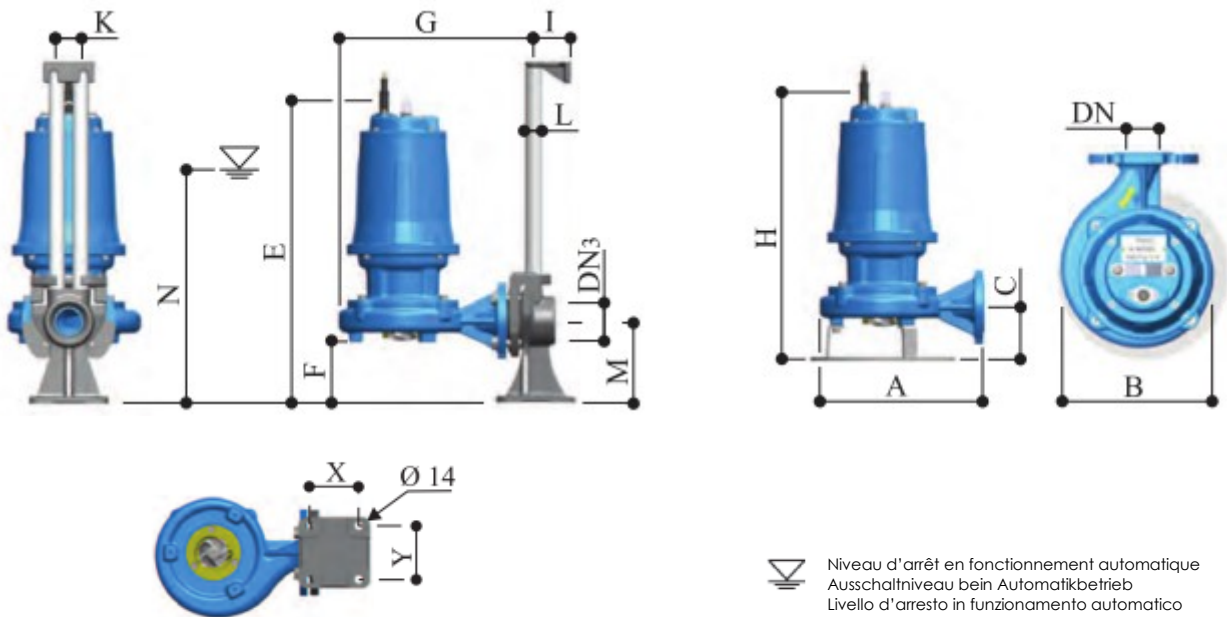

Type / Typ / Tipo	E	F	G	I	K	L	M	N	X	Y	H	A	B	C
MASTER 4 - 5 M/T (A)	480	95	310	59	37.5	3/4"	130	410	85	94	442	268	210	92