

MASTER 2-3

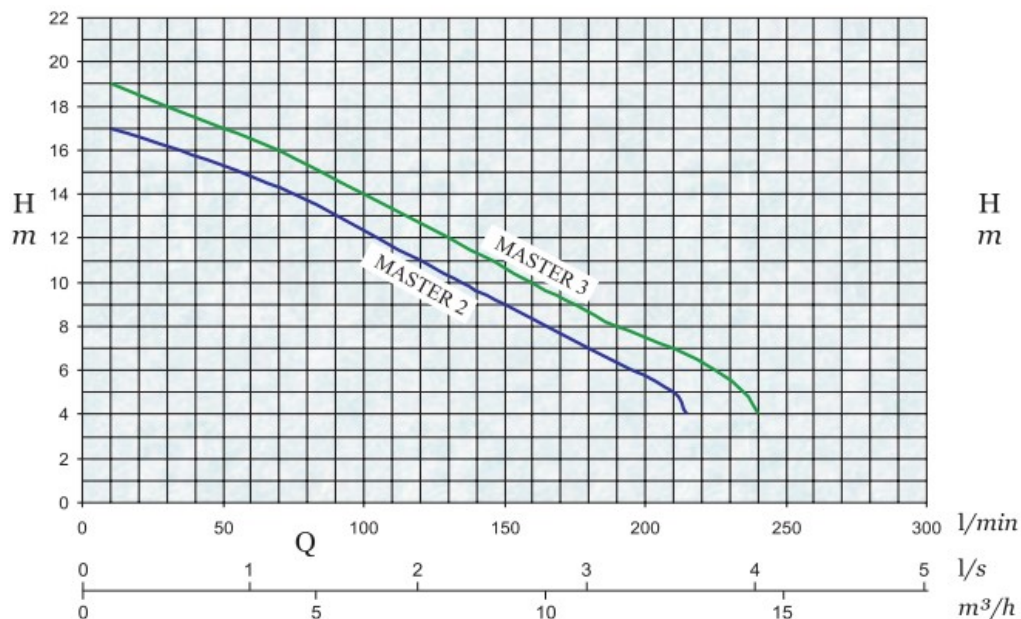

Passage libre 6 mm
Freier Durchgang 6 mm
Passaggio libero 6 mm



Type Typ Tipo	n [t/min] [U/min]	P [kW]	1 ~ 230 V		3 ~ 400 V I [A]	f [Hz]	DN ["G]	DN3 ["G]	Poids [kg] Gewicht [kg] Peso [kg]
			I [A]	C [µF]					
MASTER 2 M/T (A)	2850	0.9	7.3	30+70	2.5	50	1 1/4"	2"	23
MASTER 3 M/T (A)	2850	1.1	9.1	30+70	3.0	50	1 1/4"	2"	25

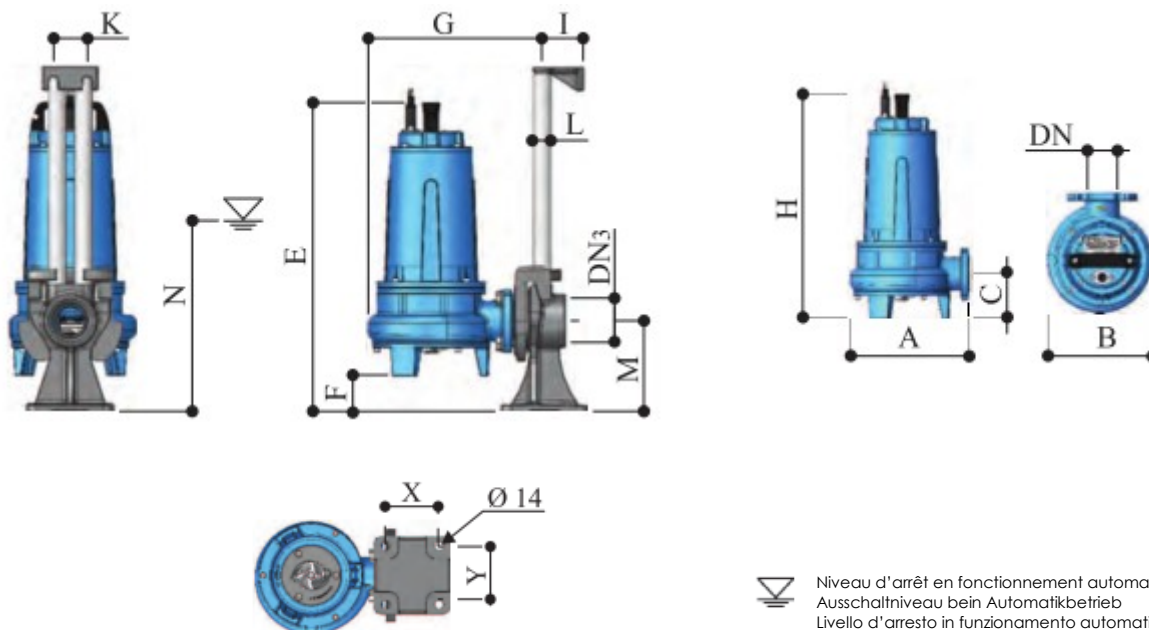

Type / Typ / Tipo	E	F	G	I	K	L	M	N	X	Y	H	A	B	C
MASTER 2 - 3 M/T (A)	437	52	292	59	37.5	3/4"	130	330	85	94	385	205	185	78

VOGEL POMPES SA se réserve le droit de modifier sans préavis les données techniques de ce catalogue.

VOGEL PUMPEN AG behält sich das Recht vor die technischen Daten dieses Katalogs fristlos abzuändern.

VOGEL POMPES SA si riserva di modificare senza preavviso i dati ripartati in questo catalogo