

ENERGY 9

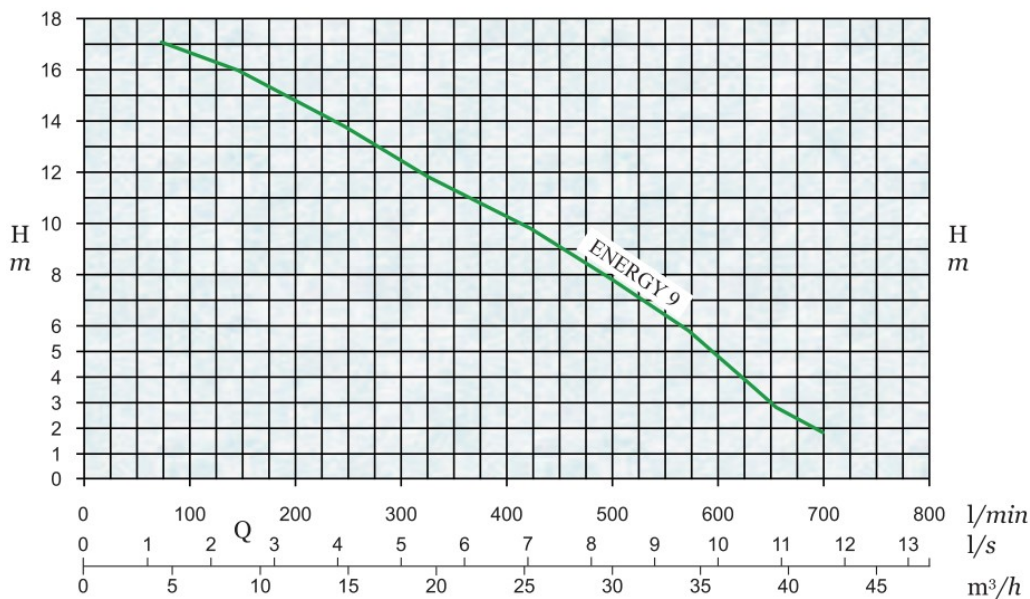

Passage libre 50 mm
Freier Durchgang 50 mm
Passaggio libero 50 mm



Type Typ Tipo	n [t/min] [U/min]	P [kW]	3 ~ 400 V 230 V I [A]	f [Hz]	DN ["G]	DN3 ["G]	Poids [kg] Gewicht [kg] Peso [kg]
ENERGY 9 T	2850	2.2	5.3	50	2"	2"	26.0

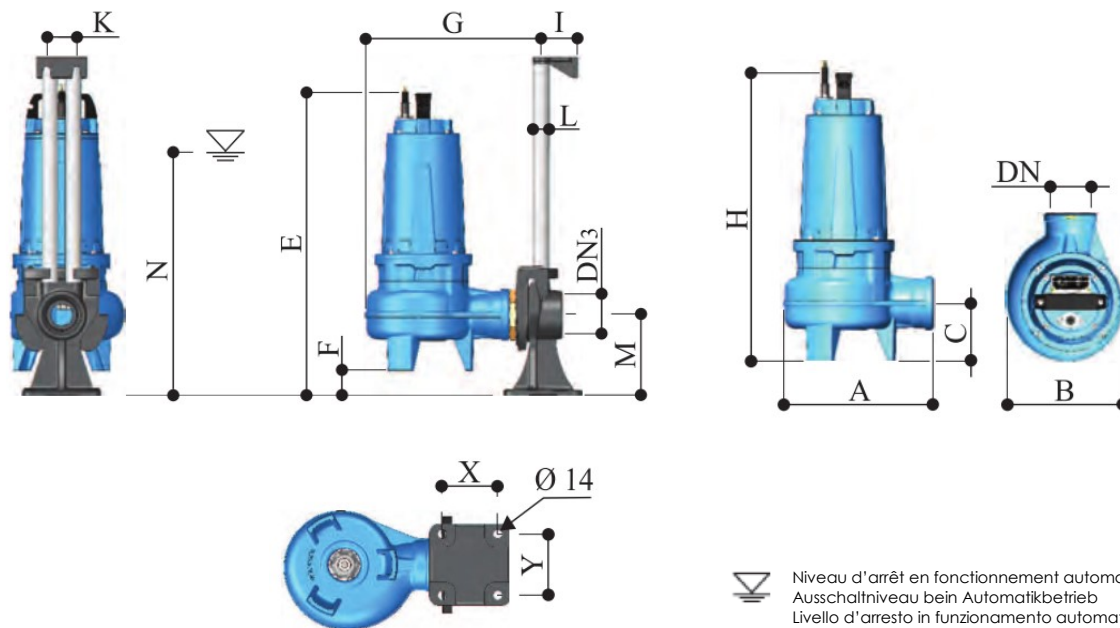

Type / Typ / Tipo	E	F	G	I	K	L	M	N	X	Y	H	A	B	C
ENERGY 9 T	485	51	283	59	37.5	¾"	130	375	85	94	445	232	184	89